



**Invitation for Bid No. 2022-054**

**Chain Link Fencing Storage Area(s)**

---

**ADDENDUM No. 1**

**ISSUE DATE: April 22, 2022**

Responding Bidders on this project are hereby notified that this Addendum shall be made a part of the above named IFB document.

The following items add to, modify, and/or clarify the IFB documents and shall have the full force and effect of the original Documents. This Addendum shall be acknowledged by the Offeror in the IFB document.

**A) Add/Delete/Replace**

**1. Section 6.1 Commercial Chain Link Fence, D. Swing Gate Post, pg.9**

**Delete:** Schedule 80, NPS 4" OD

**Replace with:** Schedule 40, NPS 6" OD

**2. Delete:** In its entirety Section 6.2, Drawings

**Replace with** the attached updated Section 6.2, Drawings

**3. Delete:** Appendix A – Price Form

**Replace with** the attached updated Appendix A – Price Form

**Attachment: 6.2 Drawings**

**Attachment: Appendix A – Price Form**

## Addendum #1

### 6.2 DRAWINGS

The Special Events Center at Jesse Helms Park - Chain Link Fencing Storage Area(s) Project

The Special Events Center at Jessie Helms Park  
Storage Area #1 – Left Side of Arena Looking Out

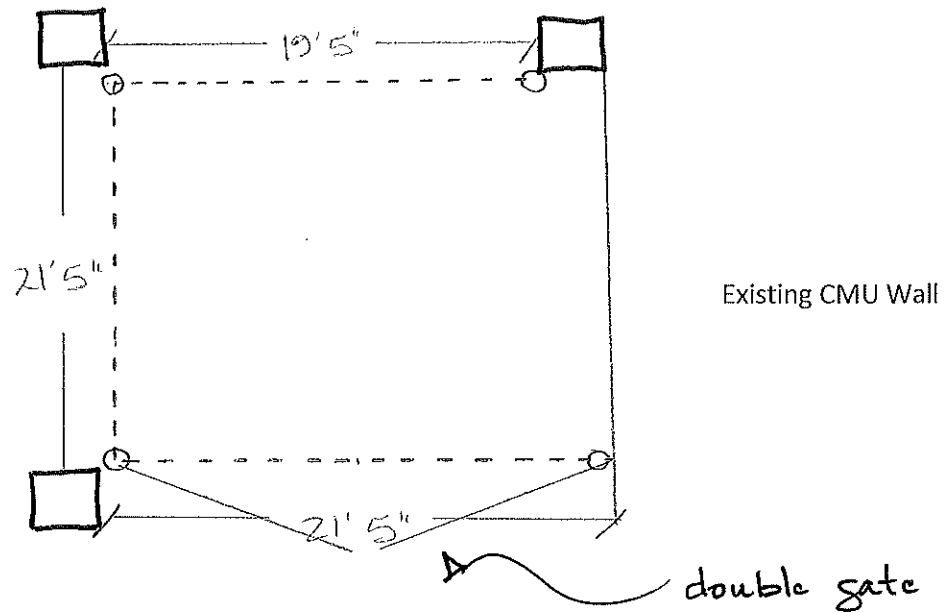

- Dimensions are shown to reflect the approximate distance between existing columns
- Fence, post and gate to be installed in concrete slab along existing control joint, shown as a dashed line -----

The Special Events Center at Jessie Helms Park  
Storage Area #2 – Right Side of Arena Looking Out

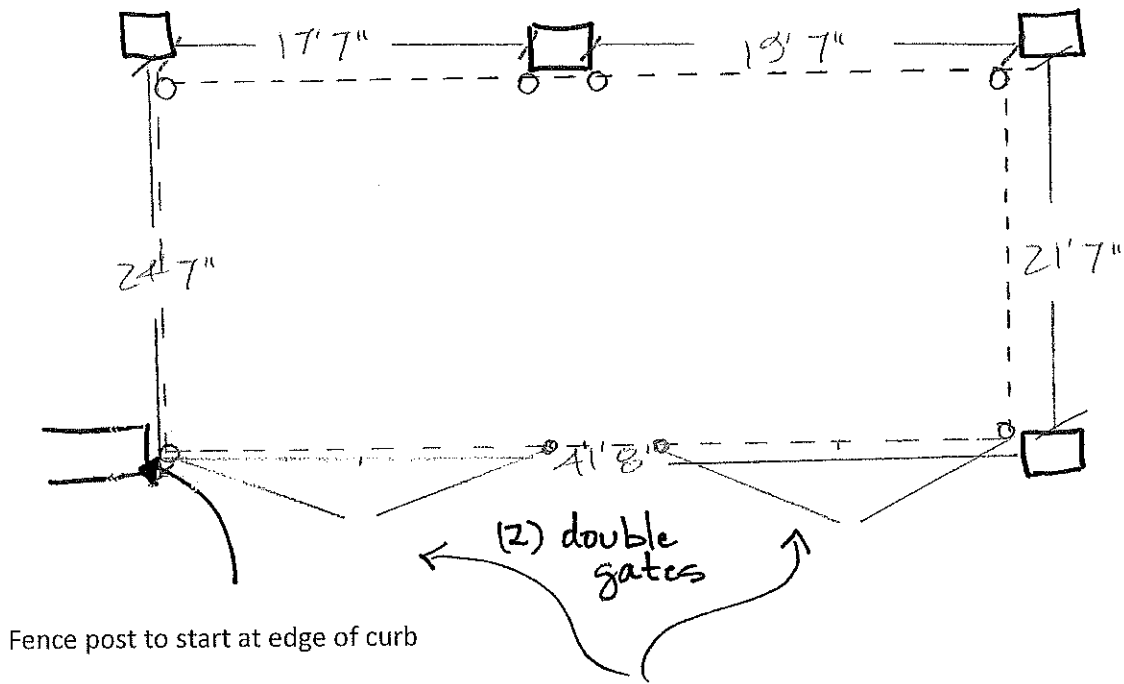

- Dimensions are shown to reflect the approximate distance between existing columns
- Fence, post and gate to be installed in concrete slab along existing control joint, shown as a dashed line -----

## Typical fence Sections Between Columns

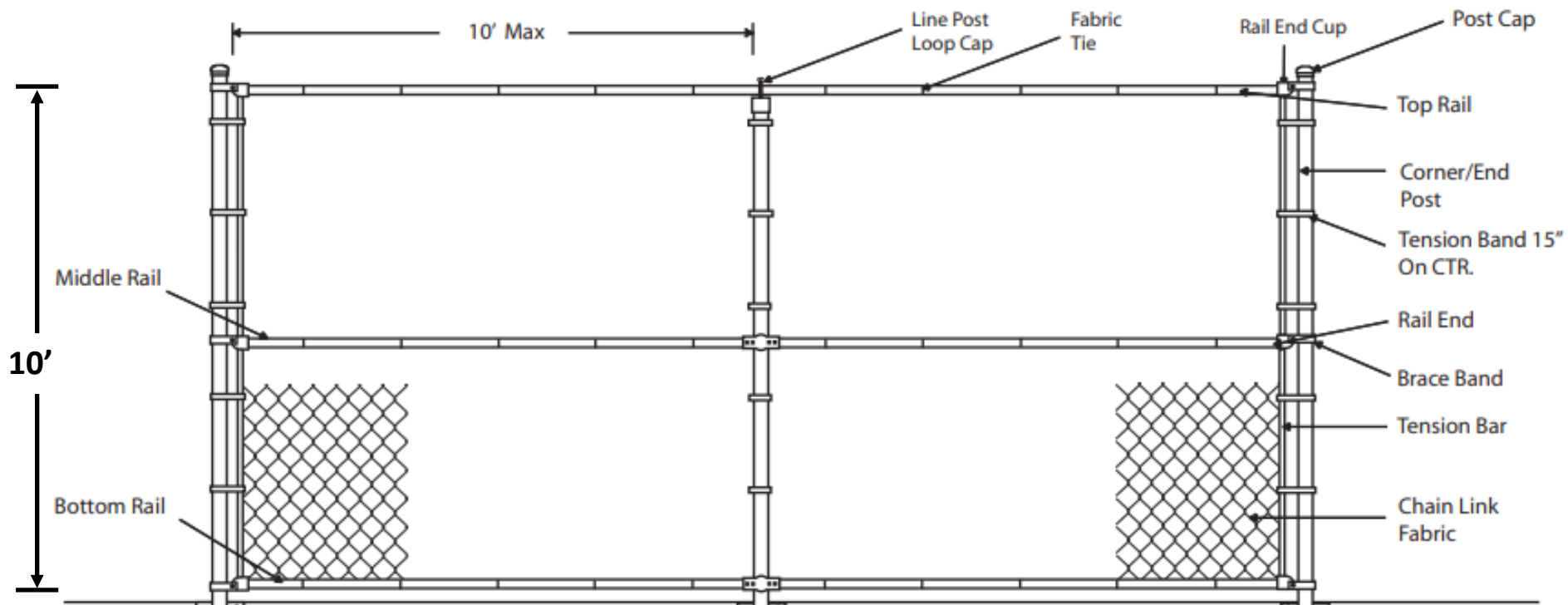

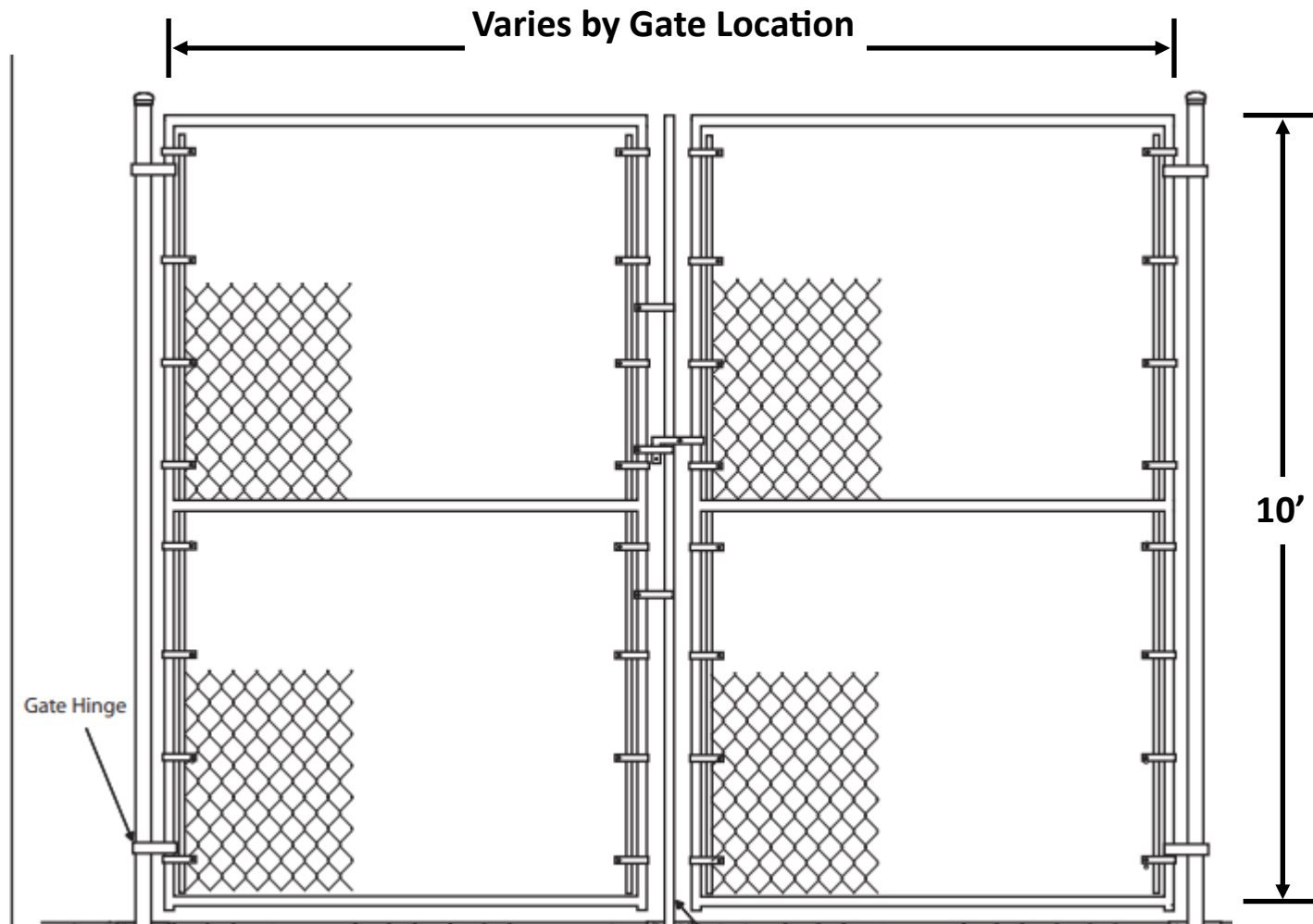

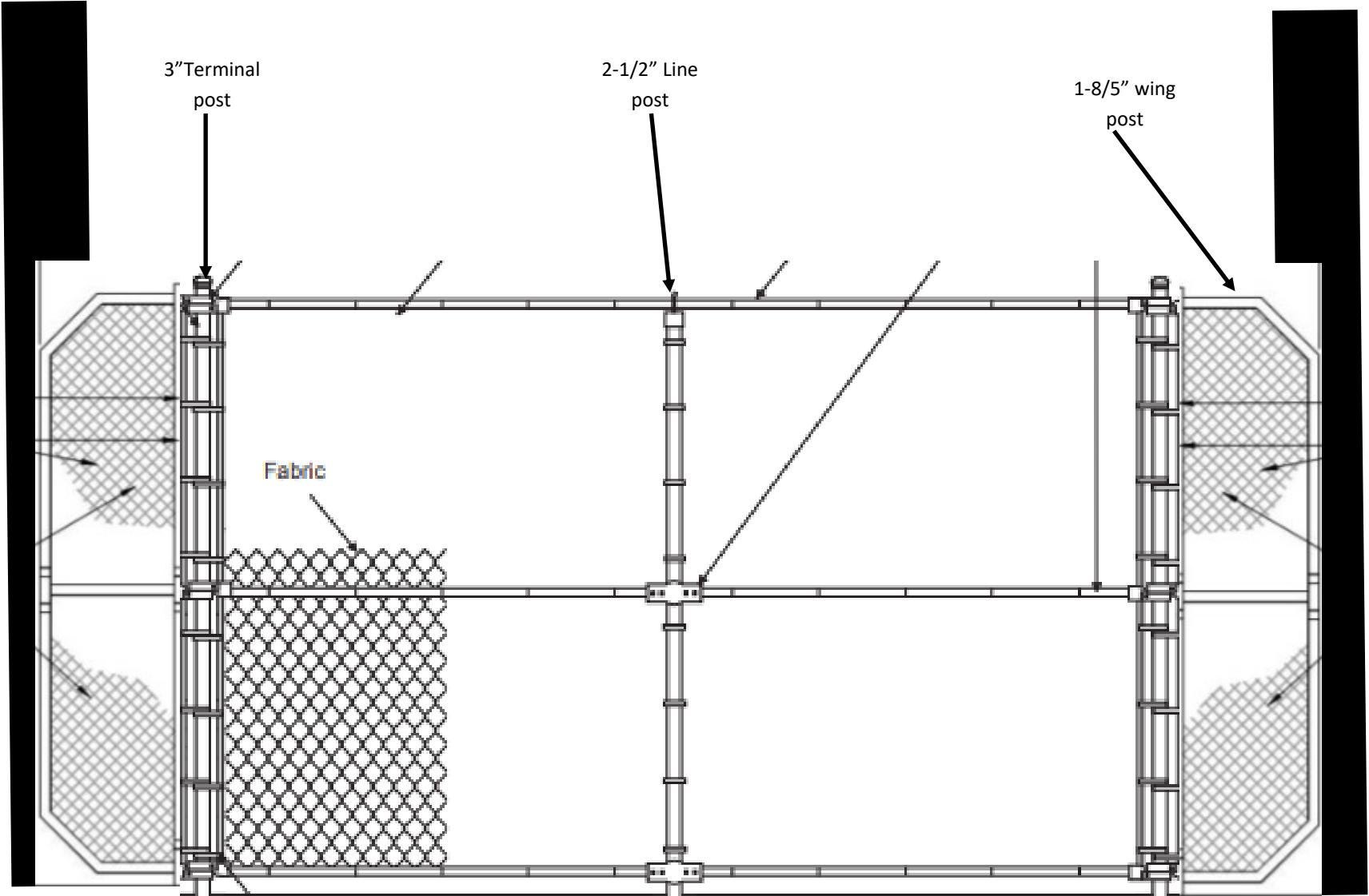



**Addendum #1 - Price Form**

**9 APPENDIX A – PRICE FORM**

**IFB 2022-054 Chain Link Fencing Storage Area(s)  
SUBMIT WITH BID**

**Failure to complete the following form(s) shall result in your bid being deemed non- responsive and rejected without any further evaluation.**

The turn-key price must include, but is not limited to all labor, materials, delivery, and warranty as described in **Section 6.1** above. Service/installation is included in Lump Sum Turn-Key Price. Bidder will complete the Work in accordance with the Scope of Work and Contract Documents for the following price(s):

<b>Jesse Helms Storage Area #1 (refer to section 6.2)</b>				
Description	Est. Qty.	Unit	Unit Price (Per Linear Foot)	Subtotal (Est Qty x Unit Price)
Materials	57	Linear Feet		
Installation	57	Linear Feet		
<b>Total Turn-Key Price for <u>Storage Area #1</u> (Subtotal of Materials + Installation)</b>				
<b>Jesse Helms Storage Area #2 (refer to section 6.2)</b>				
Description	Est. Qty.	Unit	Unit Price (Per Linear Foot)	Subtotal (Est Qty x Unit Price)
Materials	120	Linear Feet		
Installation	120	Linear Feet		
<b>Total Turn-Key Price for <u>Storage Area #2</u> (Subtotal of Materials + Installation)</b>				
<b>Grand Total Bid:</b>				
<b>(Storage Area #1 Subtotal + Storage Area #2 Subtotal)</b>				

**Note:** Bidders must complete Unit Price, Subtotal(s) and Total Turn Key Price for Storage Area #1 and Storage Area #2, as well as the “Grand Total Bid” above in order to be deemed lowest responsive and responsible. Union County reserves the right to award based on the total turn key price for Storage Area #1 and/or Storage Area #2, or the “Grand Total Bid” price indicated above.

Bidder acknowledges that Total Lump Sum Turn-Key Price includes an amount considered by Bidder to be adequate to cover Contractor's overhead and profit for the complete project.

Company Name: \_\_\_\_\_

Compliance of Warranty as stated in Section 6.1: \_\_\_\_\_

Attach list of Subcontractors:

**\*\*End of Price Form\*\***

\*\*\*\*\*

**END OF ADDENDUM No.1**